

HEAVY DUTY

HAND PALLET TRUCK

DOWN WITH HARD WORK

The Heavy Duty (C8) is the logical choice for your toughest tasks. It features an extended load capacity of 8,000 lbs., a reinforced frame, solid steel wheels, rollers and a heavy duty hydraulic pump, making it a force to be reckoned with in any environment.



LIFFRITE
KEEPS YOU MOVING

HEAVY DUTY

HAND PALLET TRUCK

FOR ORDERS OR INQUIRIES CALL 1.800.558.6012 OR EMAIL HPTORDERS@LIFTRITE.COM

FLEXIBILITY

With a reinforced frame, handling loads of 8,000 lbs. won't be a problem.

DURABILITY

Hour after hour. Day after day. Year after year. The solid steel wheels, rollers and heavy hydraulic pump withstand the most demanding applications.



Solid steel wheels and rollers



Ergonomic loop handle



Heavy duty hydraulic pump

Durable powder coat finish

Due to continuous product improvement, specifications are subject to change without notice or obligation. Some systems and features shown are optional at extra cost. Lift-Rite is a U.S. trademark of Lift-Rite.

SPECIFICATIONS:

C811LY00-000

- » Capacity: 8,000 lbs
- » Fork Length: 48 inches
- » Frame Width: 27.00 inches
- » Fork Width: 7.00 inches
- » Low Height: 3.25 inches
- » Raised Height: 7.75 inches
- » Wheel Diameter: 7.00 inches
- » Wheel Type: Steel
- » Roller Diameter: 3.00 inches
- » Roller Type: Steel
- » Weight: 285 lbs

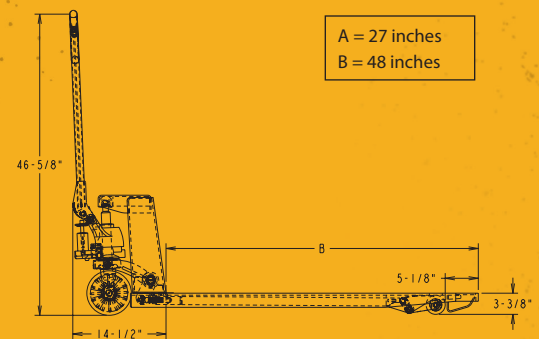
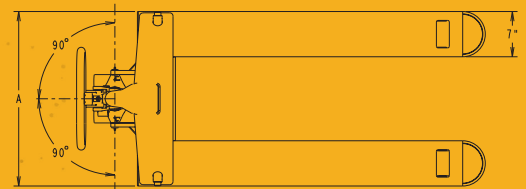

LIFT-RITE
KEEPS YOU MOVING

©2016 Lift-Rite
PO Box 130, Greene, NY 13778-0130
www.liftrite.com | Toll free 1-800-558-6012
LR-1013

HEAVY DUTY

HAND PALLET TRUCK

DOWN WITH HARD WORK

The Heavy Duty (C8) is the logical choice for your toughest tasks. It features an extended load capacity of 8,000 lbs., a reinforced frame, solid steel wheels, rollers and a heavy duty hydraulic pump, making it a force to be reckoned with in any environment.



LIFFRITE
KEEPS YOU MOVING